

ADAT-4 User Guide

ADAT-to-AES converter



Printing History

SoundPals™ ADAT-4 ADAT-to-AES converter

Rev. N/C

March 2007

Printed in U.S.A.

Part Number **08-2054-00**

The information contained in this guide is subject to change without notice or obligation.

Copyrights and Trademarks

© 2005 GRAHAM-PATTEN SYSTEMS, INC.

Contents of this publication may not be reproduced in any form without the written permission of Graham-Patten. Reproduction or reverse engineering of copyrighted software is prohibited.

FCC Compliance

This equipment has been tested and found to comply with the limits for a Class A digital device pursuant to Part 15 of the FCC Rules. These limits are designed to provide reasonable protection against harmful interference when the equipment is operated in a commercial environment. This equipment generates, uses, and can radiate radio frequency energy and, if not installed and used in accordance with the instruction manual, may cause harmful interference to radio communications. Operation of this equipment in a residential area is likely to cause harmful interference in which case the user will be required to correct the interference at your own expense.

Warranty Statement

Graham-Patten warrants that the equipment it manufactures is free from defects in workmanship and materials and meets applicable published specifications. Equipment that has been operated within published ratings and has not been subjected to abuse or modification, and which fails because of such defects, will be replaced or repaired at the Company's discretion if it is returned, freight prepaid, to Graham-Patten within seven years of receipt.

This warranty supersedes all other Warranties, express or implied. Graham-Patten is not liable for any consequential damages.

Company Address



GRAHAM-PATTEN SYSTEMS, INC.
119 East McKnight Way, Unit A
Grass Valley, California 95949
Telephone: (888) 622-4747, (530) 477-2984
Fax: (530) 477-2986
e-mail: info@isis-group.com
World Wide Web: www.gpsys.com

Graham-Patten is a division of



Table of Contents

Table of Contents	ii
Introduction	1
What are SoundPals?.....	1
Documentation Conventions.....	1
Signals and Values.....	1
Warnings.....	1
Unpacking and Inspection.....	2
Power Supply Note.....	2
ADAT-4	3
About the ADAT-4.....	3
ADAT-4 Installation.....	4
Connecting Power.....	4
Connecting the ADAT Input.....	4
Connecting the ADAT Outputs.....	4
ADAT-4 Operation.....	5
ADAT-4 Interconnection.....	5
ADAT-to-AES Conversion.....	5
ADAT Bridge to AES Routing System.....	6
ADAT-4 Internal Jumpers.....	7
ADAT-4 Troubleshooting.....	9
ADAT-4 Specifications.....	9
Audio Specifications.....	9
Environmental Specifications and Dimensions.....	10
Channel Routing.....	10
Inside the Module	11
In This Section.....	11
Before You Begin.....	11
Opening the Module.....	11
Closing the Module.....	11
External Power	12
About Power Supplies.....	12
CE Compliance.....	12
Portable Power Sources.....	12
Power Supply Specifications.....	12
Power Supply Sources.....	12

Introduction

What are SoundPals?

Each Graham-Patten SoundPals module is essentially a digital audio *building block* that can be used independently, or interconnected to perform more advanced mixing and audio processing functions.

SoundPals can be used in both standalone and system configurations:

- In a “standalone” configuration, each SoundPals module is designed to perform a specific audio processing function such as ADAT-to-Analog conversion. In this way, each module functions as a perfect low-cost adjunct to larger mixing consoles (such as the Graham-Patten D/ESAM series) — for single-purpose processing tasks.
- In a “system” configuration, SoundPals can be *linked* to form more comprehensive digital audio tools. For field recording, studio applications, and workstation applications, SoundPals can be used to seamlessly perform functions that would otherwise require extensive peripheral gear. Best of all, SoundPals “systems” can be re-configured quickly and easily — to suit your changing audio production requirements.

All SoundPals modules are extremely compact, rugged, and identical in size for ease of installation, interconnection, and use. In addition, SoundPals support AES3id. This allows longer, more robust AES signal distribution using standard coaxial cable. Error free distances of 1000 feet can be attained using inexpensive coaxial cables.

Documentation Conventions

The following documentation conventions are used in this guide:

- Buttons, knobs, connectors, and switches are indicated in bold-faced capital letters. For example:

Adjust the left **GAIN TRIM** to ...

- Primary sections are listed in bold text, with a line above:

Primary Section

- Secondary sections are listed in bold text, with no line:

Secondary Section

Signals and Values

Note the following important information regarding audio signal level:

- AES3 = Balanced output with 2 channels of digital audio (left and right)
- AES3id = Unbalanced output with 2 channels of digital audio (left and right)

Warnings

Please observe the following important warnings:

- Heed all warnings on the unit and in the instructions.
- Do not use this product in or near water.
- Route power cords and other cables so that they are not likely to be damaged. Disconnect power before cleaning. Do not use liquid or aerosol cleaners; use only a damp cloth.

Unpacking and Inspection

When you receive your SoundPals modules, inspect the cartons for signs of damage. Contact your dealer and the shipper *immediately* if you suspect any damage has occurred during shipping. Check the contents of each box to be sure that all parts are included. If any items are missing, contact your dealer immediately.

Power Supply Note

SoundPals are delivered with a power connector *only*. A separate power supply must be obtained. Graham-Patten offers several power solutions for both domestic and international customers. Refer to “**External Power**” for detailed power specifications for users who wish to configure their own power source, rather than purchase one from Graham-Patten.

ADAT-4

About the ADAT-4

The SoundPals ADAT-4 is an ADAT-to-AES converter that separates a single 8-channel ADAT data stream on optical fiber into four AES output audio pairs, on either balanced or coaxial cable. AES outputs are synchronous with the ADAT input.

The unit offers the following features:

- Synchronizing connector for a silent AES3id or word clock output. This output can be used to synchronize other SoundPals to the ADAT data stream.
- Front panel switch for selecting reference output
- Optional rack mounting tray (1 RU)
- Compact size, rugged construction

Two product models are available: The “A” model has AES3 outputs (XLR), and the “B” model has AES3id outputs (BNC).

The figure below illustrates the ADAT-4’s front panel:

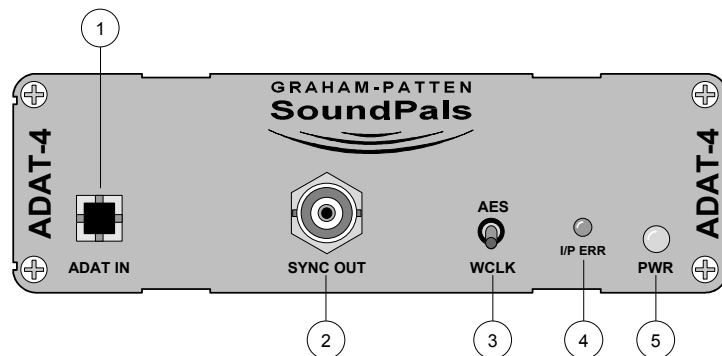

- 1) **ADAT IN** — the optical input is a standard ADAT signal using plastic fiber with a maximum range of 1 meter. The input must have a sampling frequency between 30 and 50 KHz.
- 2) **SYNC OUT** — the synchronization output can be set to either AES3id or word clock, depending on the position of the adjacent **Sync Switch**. The AES3id output uses the same channel status bit settings as the main AES outputs.
- 3) **AES/WCLK** — the two-position **Sync Switch** allows you to select either AES3id or word clock as the sync output.
- 4) **I/P ERR** — this LED lights when *no signal* is applied to the input, or when the signal is *not valid*. A non-valid signal exhibits errors such as format violations, bit errors, low level, or incorrect frequency. When lit, the output is muted.
- 5) **PWR** — the large green **Power LED** lights when system power is applied.

The figure below illustrates the ADAT-4's rear panel:

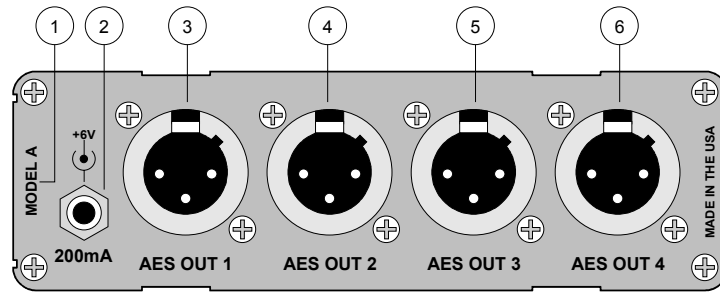

- 1) **ADAT-4 Model**— the “A” model has AES3 outputs (XLR), and the “B” model has AES3id outputs (BNC).
- 2) **Power Connector** — accepts the power jack from the 6VDC power supply. Refer to “**External Power**” for more information regarding external power.
- 3) **AES OUT 1** — output #1 is standard AES audio, either AES3 (XLR) for the A model or AES3id (BNC) for the B model. The output is locked to the ADAT input.
- 4) **AES OUT 2** — identical in function to output #1.
- 5) **AES OUT 3** — identical in function to output #1.
- 6) **AES OUT 4** — identical in function to output #1.

An internal jumper allows the outputs to have 20 or 24 active bits. In 20-bit mode, each output's auxiliary data bits will be set to zeros. Output channel status bits will reflect the 20/24-bit mode setting. Refer to the “**ADAT-4 Internal Jumpers**” for instructions on all jumper settings.

ADAT-4 Installation

This section provides instructions for connecting power, digital inputs, and digital outputs.

Connecting Power

Plug a 6VDC power supply (rated at **200 mA** or greater) into the appropriate voltage outlet for *your specific country*, and connect the end of the cord into the ADAT-4 jack marked **+6V**. Secure the locking ring finger tight. The green **PWR** LED lights when power is applied.

Connecting the ADAT Input

The ADAT optical input includes eight audio signals with synchronization words, auxiliary data bits (currently all zeros) and clock extraction bits to conform to the ADAT format. Using an approved 1-meter (or less) ADAT cable, connect the desired ADAT source to the ADAT-4's input connector.

Connecting AES Outputs

Connect the digital audio output from one of the four **AES OUT** connectors, and route it to the input of the desired destination device. Repeat the procedure for all digital outputs as required.

Refer to the “**ADAT-4 Specifications**” section for a table of ADAT-4 channel routing.

ADAT-4 Operation

This section includes instructions for operating the ADAT-4. See the “**ADAT-4 Specifications**” section for a channel routing table.

Operating procedures for the ADAT-4 are simple:

- Connect the ADAT input from the desired ADAT source.
- Connect AES outputs to the desired destinations.
- If you want to use the ADAT-4 as the reference for another device, connect the **SYNC OUT** connector to the reference input of the destination device, and use the **Sync Switch** to select either AES or word clock reference.

ADAT-4 Interconnection

This section provides two ADAT-4 interconnection diagrams.

- **ADAT-to-AES Conversion**

In this application, the ADAT optical cable is connected from an audio workstation to the ADAT-4. The AES outputs from the ADAT-4 are connected to the inputs of a D/ESAM mixer, a DAT recorder, and also to a DAC-24 for purposes of driving analog outputs and headphones.

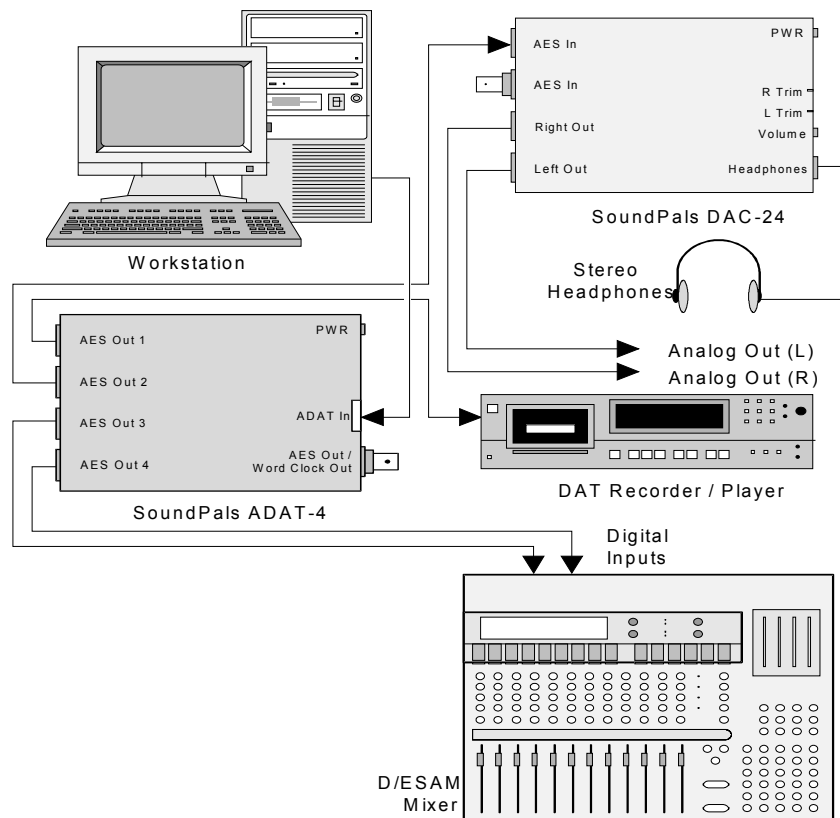

- **ADAT Bridge to AES Routing System**

In this application, the ADAT-3 and ADAT-4 combine to provide a bridge in and out of an AES routing switcher.

- ~ The ADAT-4 accepts an optical input from a source ADAT device (such as a workstation or ADAT recorder), and provides four AES outputs that feed the routing switcher.
- ~ The ADAT-3 accepts four AES inputs from the routing switcher, and provides an optical ADAT output for routing to ADAT destinations.

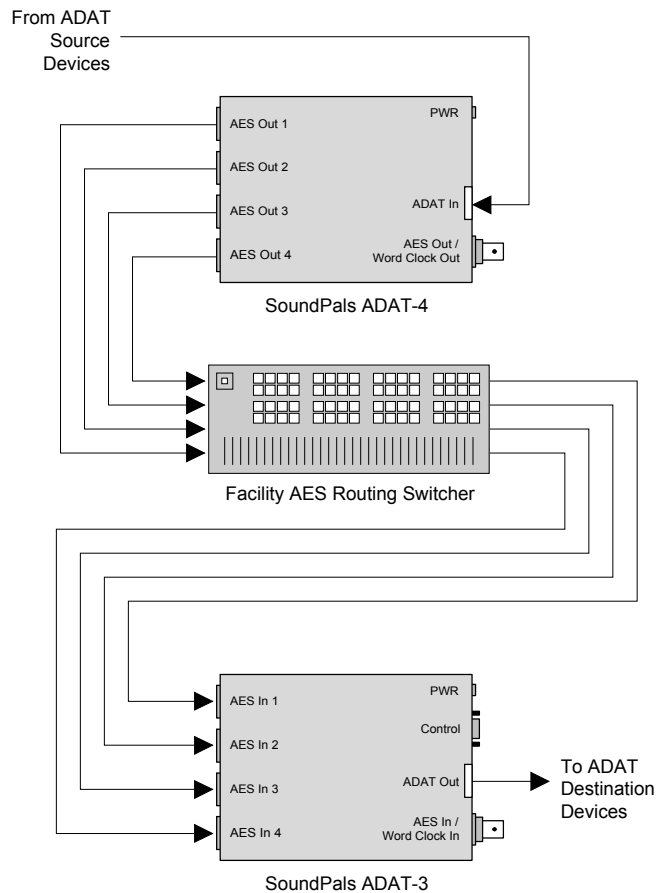





ADAT-4 Internal Jumpers

This section provides information about the ADAT-4's internal jumpers and switches.

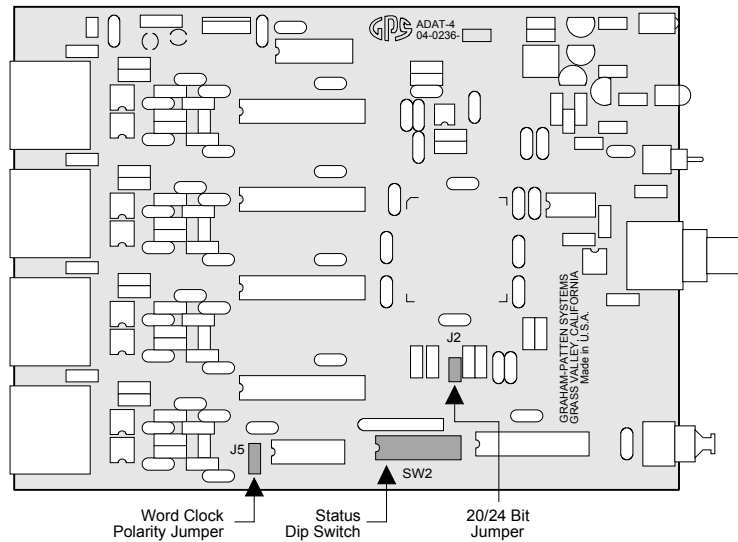
NOTE For detailed instructions on opening and closing the ADAT-4, see “**Inside the Module.**”

The figure below shows the ADAT-4's internal jumper locations:



- **J2 is the 20/24 Bit jumper.**
 - 1  – To set all 4 channels to 24 bits, install the jumper. This is the default configuration.
 - 2  – To set all 4 channels to 20 bits, remove the jumper. In 20-bit mode, any auxiliary data on the AES inputs will be discarded.
- **J5 is the Word Clock Input Polarity jumper.**
 - 1  – To leave work clock input reference normal, strap the jumper between pins 1 and 2. The rising edge is used as reference.
 - 2  – To invert the work clock input reference, strap the jumper between pins 2 and 3. The falling edge is used as reference.
 - 3

SW2 is the **Status Dip Switch** which is used to set the channel status on all AES outputs, including the **SYNC** output (provided that the **Sync Switch** is set to **AES**). The switch is an eight-position DIP, of which five switches are active.

1 (closed) top position
0 (open) bottom position

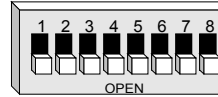

For all switches:

- ~ **0** is open
- ~ **1** is closed
- ~ The default setting is all **0**'s

- Switches **1** and **2** determine the **Emphasis**.

Function	SW1	SW2
Not Indicated	0	0
None	1	0
50/15uS	0	1
J.17	1	1

- Switches **3** and **4** determine the **Sample Frequency**.

Function	SW3	SW4
Not Indicated	0	0
48 kHz	0	1
44.1 KHz	1	0
32 KHz	1	1

- Switch **5** determines the **Stereo Mode**.

Function	SW5
Not Indicated	0
Stereo	1

ADAT-4 Troubleshooting

The table below lists ADAT-4 problems and solutions.

Problem	Procedure
No output.	<ul style="list-style-type: none"> • Check Power by Green LED.
Outputs are all silent.	<ul style="list-style-type: none"> • Check Input ERROR LED. • Verify that the source is not silent.
Input ERROR .	<ul style="list-style-type: none"> • Unplug the fiber cable and check for visible red light (this is not harmful). • If no light, unplug the cable from the source and check for visible red light from the transmitter. • Check for possible break in the fiber.

NOTE Please contact the GPS factory if the problem still exists after completing the above procedures.

ADAT-4 Specifications

This section provides audio, remote, and environmental specifications, plus a table of ADAT-4 channel routing.

Audio Specifications

Parameter	Specification
Dynamic Range	
24-bit processing	138 dB
20-bit processing	120 dB
ADAT Input	
Peak wavelength	660 nm
Input sensitivity	Adequate sensitivity to receive a signal transmitted at -17 dBm over 1 meter of plastic fiber (Sharp GP1C321) without errors.
Sample frequency	30–50 KHz
A Model — AES3 Outputs (110Ω Termination)	
Amplitude	2–7 V p-p
Rise time	5–30 ns
Output impedance	110Ω ±20% (0.1–6 MHz)
Common mode	<-30 dB (0–6 MHz)
B Model — AES3id Outputs (75Ω Termination)	
Amplitude	1 ±0.2 V p-p
Rise time	37 ±7 ns
Output impedance	75Ω
Return loss	>15 dB (0.1–6 MHz)
DC on output	<50 mV

Audio Specifications (continued)

AES3ID Synchronization Output	
Amplitude	1 ±0.2V p-p
Rise time	37 ±7 ns
Output impedance	75Ω
Return loss	>15dB (0.1–6MHz)
DC on output	<50mV
Word Clock Synchronization Output	
Amplitude	V _{LO} <0.5V at I _{OUT} = -5mA V _{HI} >4.5V at I _{OUT} = 5mA
Waveform	Square-wave at F _s
Phasing	+ edge coincident with audio sampling instant. Use jumper J5 to invert.
Options	
RT-2, 1RU rack tray for mounting up to 3 units	
Power supplies: PSU-1, 90-260V 50/60Hz in-line power supply with detachable IEC power cord	

NOTE All specifications listed above subject to change without notice.

Environmental Specifications and Dimensions

Parameter	Specification
Dimensions (less connectors)	5.2W x 1.62H x 6.625D 13.2 x 4.1 x 16.8 cm
Power	<200mA @ 6Vdc
Operating Temp	10 – 50 °C
Operating Humidity	10 – 90% RH non-condensing

Channel Routing

The table below lists ADAT-to-digital channel routing in the ADAT-4:

ADAT Input Track	AES Output
1, 2 →	1
3, 4 →	2
5, 6 →	3
7, 8 →	4

Inside the Module

In This Section

This section provides instructions for opening and closing the SoundPals SDDM-8 module to gain access to the internal circuit board.

NOTE The internal circuit board should only be removed from the module if you want to change the jumpers.

Before You Begin

Check the following items before opening the module and attempting to remove the internal circuit board:

- If required, remove the SoundPals module from the rack tray.
- Disconnect the power supply from the front of the product.
- Disconnect all input, output and control cables.
- Perform the remaining steps *only* in a static free environment. Make sure that *you and the product* are both grounded.

The following tools are required:

- #2 Phillips screwdriver
- 9/16 box wrench (or end wrench)

Opening The Module

Use the following steps to open a SoundPals module:

1. On the rear panel, remove the four Phillips screws from the four corners of the SoundPals module.
2. On the front panel, remove all Philips XLR mounting screws from the SoundPals module.
3. On the front panel, remove the BNC nut and associated lock washer.
4. Pulling the rear panel, carefully draw the internal circuit board and rear panel assembly from the housing.

CAUTION Keep the case horizontal so that the BNC bushing stays with the connector.

5. Set the housing and all mounting hardware in a safe place.

Closing The Module

Use the following steps to close a SoundPals module:

1. Ensure that the product label is on the bottom.
2. Carefully slide the internal circuit board and rear panel assembly through the housing. Keep the case horizontal so that the BNC bushing stays with the connector.
3. Replace the BNC nut and associated lock washer on the front panel of the module.
4. Replace all Phillips XLR mounting screws on the front panel of the module.
5. Replace and tighten the four Phillips screws on the rear corners of the module.

CAUTION Do not over tighten the screws.

External Power

About Power Supplies

An external power supply conforming to the specifications listed in the following “**Power Supply Specifications**” section *must be used* to guarantee that published SoundPals performance figures are met. Any power supply meeting these specifications will supply adequate power for a single SoundPals module. Although the specification is written for power supplies running from AC line inputs, DC (battery) sources may be used if they meet all of the listed requirements.

CE Compliance

For CE compliance, the power supply that you use *must comply* with the following requirements:

- Low Voltage Directive 73/23/EEC
- EMC Directive 89/336/EEC
- EMC Directive 93/68/EEC
- The connector locking ring must be tight.

Portable Power Sources

For portable SoundPals power sources, sealed lead-acid, nickel cadmium or alkaline primary batteries may be used. However, the maximum voltage must *not* exceed 8.6 volts, and a minimum of 5.6 volts is required for normal operation. Maximum current drain will be 215mA.

Power Supply Specifications

The following specifications must be met over all anticipated operating conditions including AC power line range, temperature range, etc.

Parameter	Specification
Output voltage	5.6V minimum (measured at trough of ripple) at 215 mA constant current. 8.6V maximum (measured at peak of ripple) at 140 mA constant current.
Ripple voltage	2V p-p at 700 mA constant current. 400mV p-p at 700mA constant current with external 2200 μ F capacitor.
Connector	Switchcraft 761K with center positive, sleeve negative.

Power Supply Sources

In addition to the GPS-supplied universal power supply, the following power supplies meet the SoundPals requirements:

Company	Model	Note
Stancor	STA-4860	120V AC, 60 Hz
Stancor	STAF-0797F	220V AC, 50 Hz with European wall plug (CE compliant).
Elpac	MI2007	95-250V AC, 47-63 Hz with IEC inlet (line cord required). Will power up to six units (CE compliant).